

PATENT SPECIFICATION

(11) 1 232 104

DRAWINGS ATTACHED

1 232 104

- (21) Application No. 32482/68 (22) Filed 8 July 1968
(45) Complete Specification published 19 May 1971
(51) International Classification B 01 d 15/08
(52) Index at acceptance
BIX 3X1
(72) Inventors WOLFGANG RADOWITZ
HEINRICH KRIEGSMANN



(54) IMPROVEMENTS IN AND RELATING TO SEPARATING CHAMBERS FOR USE IN THIN LAYER CHROMATOGRAPHY

(71) We, DEUTSCHE AKADEMIE DER WISSENSCHAFTEN ZU BERLIN, of 5, Rudower Chaussee, Berlin-Adlershof, Germany, a Corporation organised under the laws of Eastern Germany, do hereby declare the invention, for which we pray that a patent may be granted to us, and the method by which it is to be performed, to be particularly described in and by the following statement:—

This invention relates to a multiple purpose separating chamber for the selective application of various operative techniques of thin layer chromatography, such as ascending, descending, horizontal and continuous flow chromatography, using more particularly thin layer carriers in the form of plates, films or bars. The multiple purpose separating chamber according to the invention can be used with optimum chamber saturation, optimum separating efficiency and relatively low consumption of mobile phase in both single and multiple constructions, and is suitable more particularly in series arrangements in conjunction with a device for the reception and tilting of said separating chambers for testing the mobile phase for qualitative and quantitative serial tests and physico-chemical tests, also for preparative purposes. Furthermore it can be used for tests at various temperatures, more particularly for low temperature thin layer chromatography, and for activating the thin layer carriers before development in the actual multiple purpose separating chamber, and also permits operating in a gas or inert gas atmosphere.

It is the underlying object of the invention to provide a multiple purpose separating chamber for thin layer chromatography which permits the application of a plurality of operative techniques for thin layer chromatography whilst using various formats of plate-shaped, film-shaped or bar-shaped thin

layer carriers, and with optimum separating efficiency, optimum chamber saturation at relatively low consumption of the mobile phase, can be used chiefly in series arrangement for qualitative and quantitative tests and for activating thin layer carriers, and for preparative purposes, and which permits operating in a gas or an inert gas atmosphere.

To this end, the present invention consists in a multiple purpose separating chamber of circular cross section for the optional application of various operative techniques of thin layer chromatography, the chamber comprising a tube closed at at least one of its ends by a cap, one of more thin layer carriers being disposed in the tube and retained by spacing elements, the end or each end of the tube closed by a cap being arranged to form a ground joint with the cap, the said cap or one of the caps carrying a gas outlet.

The thin layer carriers may be in form of plates, films or bars. The spacing elements may be fixedly or removably arranged in the tube. Advantageously, the cap or each cap is exchangeable and constructed as a container for the reception of a mobile phase. Preferably, one of the caps carries a gas inlet.

A particular advantage of the multiple purpose separating chamber is its exchangeable and functionally versatile mode of construction, which makes a wide range of multiple purpose use possible. Special reference should be made here to the possibility of combining a number of multiple purpose separating chambers of one or of a plurality of structural forms to form a series. The combination forming a series arrangement is extremely advantageous, principally for series tests which are required to be performed, e.g. with various mobile phases, various thin layers carriers, and various thin layer chromatographic

[Price 25p]

operative techniques. The construction of the multiple purpose separating chamber according to the invention furthermore in the conjunction with a device for the reception and tilting of a plurality of separating chambers makes it possible to conduct series tests with equal beginning and end points and hence results in reproducible R_F -values over a series of chromatographed substances.

In order that the invention may be more readily understood, reference is made to the accompanying drawings which illustrate diagrammatically and by way of example several embodiments thereof, and in which:

Figure 1 is a sectional view of one embodiment of multiple purpose separating chamber for ascending chromatography, shown in the tilted position, i.e., the position before commencement and at the end of the chromatography;

Figure 2 is a perspective view of a multiple purpose separating chamber in series arrangement conjunction with a device for the reception and tilting of a plurality of separating chambers in application as an apparatus for testing the mobile phase;

Figure 3 is a sectional view of another embodiment of multiple purpose separating chamber, wherein the tube is connected at one end to a branch container arranged at an acute angle, the branch container being adapted for closure and constructed for the reception of a mobile phase, and having a tap for use as a gas inlet or a gas outlet, this embodiment also is shown in the tilted position, i.e. the position adopted before the beginning and at the end of the chromatography;

Figure 4 is a sectional view of a further embodiment of multiple purpose separating chamber for descending chromatography provided with a thin layer plate, a paper bridge for the mobile phase, a cap with an annular trough and a cap with a hollow bulb;

Figure 5 is a sectional view of another embodiment of multiple purpose separating chamber for horizontal and continuous flow chromatography with a thin layer plate, a paper bridge for the mobile phase, a cap with a rounded bulb and a closure cap with passage for passing the thin layer plate;

Figure 6 is a detail of an interchangeable cap constructed as a rounded bulb as shown in Figures 4 and 5 for reception of the mobile phase, for the application of ascending, descending, horizontal and continuous flow operative techniques;

Figure 7 is a detail of another interchangeable cap as shown in Figures 4 and 5 constructed as a hollow bulb for reception of a mobile phase for the application of ascending, horizontal and continuous flow operative techniques;

Figure 8 shows an alternative part-spherical closure cap having spike brackets arranged oppositely on its inner wall, and a trough for a mobile phase supported exchangeably and rotatably between the spike brackets for reception of a mobile phase for the application of descending, horizontal and continuous flow operative techniques;

Figure 9 is a plan view of the trough for a mobile phase in the cap of Figure 8;

Figure 9a is a side view of the trough shown in Figure 8;

Figure 10 is a sectional view of an elbow tube-like alternative cap, adapted for closure, with recesses for retaining an insertable trough for a mobile phase for the application of descending, horizontal and continuous flow operative techniques;

Figure 11 is a perspective view of an elastic clamp for retaining a paper bridge for the mobile phase, more particularly for the application of descending, horizontal and continuous flow operative techniques;

Figure 12 is a perspective view of a hollow cylindrical tripod stand with a depression for reception of thin layer carriers of differing length;

Figure 13 is a perspective view of a vertically adjustable, hollow cylindrical tripod stand with a depression for reception of thin layer carriers of variable length and a guide-tube inside the cylindrical tripod stand for stable mounting of an insertable trough with a guide-bar as shown in Figure 14;

Figure 14 is a perspective view of a trough for isolating substances with a guide-bar for stable mounting into the hollow cylindrical tripod stands of Figures 12 and 13;

Figure 15 is a side elevation of an alternative spacing element for retaining four shaped thin layer bars; and

Figure 16 is a plan view of Figure 15. The multiple purpose separating chamber according to the invention comprises a tube 1 (see Figures 1, 4 and 5) open at both ends, which carries at each of its ends an external ground joint 3 and either one of the alternative caps 10, 11, 12, 13 (see Figures 1, 4-6, 8 and 10) which are formed as containers for reception of a mobile phase 5, or a closure cap 14, as appropriate for the proposed operative techniques for which the chamber is to be used. The tube 1 may be provided internally with spacing elements 8 (see Figures 1, 3, 4 and 5) or 9 (see Figures 15, 16) arranged fixedly or for insertion into the tube, for retaining one or a plurality of thin layer carriers of various formats (see thin layer plate 6 in Figures 1, 3-5 and 11 and thin layer bar 7 in Figures 15 and 16).

For the application of the most usual operative technique, ascending chromatography, the cap 10 provided with an internal ground joint 3 and shaped as a hollow rounded bulb 15 for reception of a mobile phase 5, may be fitted to one end of the tube 1 as shown in Figure 1.

In the case of operating in an inert gas atmosphere, which is important particularly in the case of chromatography of sensitive biochemical substances, the cap 11 is preferably fitted. The other end of the tube 1 carries the closure cap 14 with a gas outlet which may be opened by being made to coincide with an aperture 18 in the ground glass surface 3. By rotating the closure cap 14, the gas outlet is moved away from the aperture 18 and thus closed.

By virtue of the provision of the gas outlet aperture 18 capable of gas-tight closure, the multiple purpose separating chamber according to the invention can also be used for activation of the thin layer carriers before the chromatography in the actual separating chamber, since in this case the multiple purpose separating chamber can be closed in a gas-tight manner while the temperature changes of the activation are taking place, and can simultaneously be a storage chamber for the activated thin layer carriers until the chromatography is performed. The application of this mode of operation is important more particularly with the use of aluminium oxides of various degrees of activity.

The tilted position of the tube 1, in the region of approximately 45° (the tube is shown in Figure 1 of the drawing not at this angle but more nearly horizontal for considerations of space) is the position for the separating chamber before the commencement and at the end of the chromatography when fitted with any of the caps 10, 11, 12 or 14. In this position the mobile phase 5 does not come into contact with the thin layer plate 6 or with the thin layer carriers; this occurs only upon tilting into the chromatography position. Before the beginning of chromatography an optimum chamber saturation by the mobile phase vapours has occurred for the separating chamber and especially for the coated thin layer carriers (presaturated thin layer carriers); this is impossible in the conventional way of chromatography. If required the chamber saturation can be further accelerated by the convenient insertion of a strip of chromatography paper.

By means of the operative technique previously described, and more particularly in the case of series arrangements of the multiple purpose separating chamber in conjunction with a tilting device 26 (Figure 2) known *per se*, a uniform commencement and termination of the chromatography is

ensured with optimum chamber saturation, and thus exact reproducibility of the R_f values of chromatographed substances.

For a mobile phase test apparatus, a plurality of multiple purpose separating chambers in series arrangement are mounted in an insert frame 27 for tilting and/or rotation. The individual separating chambers are mounted in depressions 28, adjustable mounting bars 29 and an exchangeable, vertically adjustable clamping cover 30 lined with foam rubber. The tilting and/or rotation of the insert frame 27, which is supported for rotation in a frame structure 31 by means of a bearing 32, is effected through a lockable crank handle 33, which is movable and lockable within a semi-circular guide rail with goniometer 34. Tilting and/or rotation of the insert frame 27 may also be effected through a spindle gear driven by a motor. The described apparatus 26 is also suitable, in conjunction with the multiple purpose separating chambers, for other series tests and permits tilting movement through a range of 180°.

The multiple purpose separating chamber according to the invention furthermore renders possible chromatographic tests at various temperatures, such as tests by low temperature thin layer chromatography, by placing the chamber in a thermostatic bath.

Figure 3 shows another embodiment of the multiple purpose separating chamber according to the invention, which is also capable of application for ascending operative techniques, and comprises a vessel 2 of circular cross-section, which carries at its open end an external ground joint 3, and a closure cap 14. To the base 21 of the vessel 2 is fitted a container 22 for reception and tilting of a mobile phase 5, the container 22 meets the vessel 2 at an acute angle and is adapted for closure by a two-way valve 20. The tilted position of the vessel 2 with the container 22, in a range of approximately 45°, embraces the position before the commencement and at the end of the chromatography. The container 22 contains in this position the mobile phase 5; during the chromatographic process, the mobile phase 5 is located in the vessel base 21. The gas outlet 18 is again in the form of an aperture in ground glass surface 3. By rotating the closure cap 14, the aperture can be closed. The vessel 2 is provided in this embodiment with spacing elements 8 for retaining thin layer carriers of various formats, as illustrated the spacing elements 8 are fixedly arranged.

By this construction and that of the caps 10, 11 turbulence phenomena of the mobile phase during the tilting processes are obviated and the required uniform flow of the mobile phase is always obtained.

The tube 1 and the vessel 2 may be

provided alternatively with any of the caps and inserts hereinbelow described, and thus constitute embodiments of the multiple purpose separating chamber according to the invention.

For the selective application of the ascending, descending, horizontal and continuous flow techniques, a cap 11 (Figures 4 to 6), may be fitted on to one end of the tube 1. The other end is provided in the case of ascending, descending and horizontal operative techniques with a closure cap 14 which carries an internal ground joint 4. In the case of the continuous flow operative technique the closure cap 14 also contains a passage 43 (as shown in Figure 5) for passing a thin layer carrier.

In the case of descending, horizontal or continuous flow chromatography, the connection between the mobile phase 5 located in the bulb 16, and the thin layer carrier of plate 6 is established via a paper bridge 44. The position of the paper bridge 44 is fixed by a resilient clamp 45 and an eccentrically and rotably arranged bar 46. Operation in an inert gas atmosphere is rendered possible by a three way valve 19 fitted on the cap 11, which may as desired operate as a gas inlet or a gas outlet. The tap 17 on the cap 10 may likewise be used as an inlet or an outlet.

For the selective application of descending, horizontal and continuous flow operative techniques, the part-spherical cap 12 (Figure 8) adapted for closure may be fitted selectively upon the tube 1 or the circular cross-section vessel 2. When the tube 1 is used, one end is provided with the part-spherical cap 12, adapted for closure by a ground cover 35 and internal ground joint 4, on the internal wall 36 of which spike brackets 37 are oppositely arranged, between which a mobile phase trough 23 is rotably supported. The other end of the tube 1 may carry the cap 10, the closure cap 14, or in case of operation in a gas or inert gas atmosphere, the cap 11. The mobile phase trough 23 is provided on two mutually opposite sides with a T-shaped groove 38 (as shown in Figures 8 and 9a) and has a swivellable resilient clamp 40, secured to one face by means of a pin 39, for retaining a paper bridge 44. The paper bridge 44 establishes the connection between the mobile phase located in the mobile phase trough 23 and the thin layer carrier 6. The gas outlet in this embodiment of the invention is provided by the opening 60 located in the ground cover 35 of the cap 12, and can be closed by rotating the cover 35.

Referring now to Figure 10 there is shown an elbow tube-like cap 13 adapted for closure by a ground cover 41, which is provided internally with two recesses 42 for

retaining an insertable mobile phase trough 24. The cap 13 can be fitted on to one end of the tube 1 or the vessel 2 for the selective application of the descending, horizontal and continuous flow techniques.

In the case of the descending operative techniques the mobile phase trough 24 is inserted into the recess 42 nearest the ground cover 41, and in the case of the horizontal and continuous flow techniques into the recess 42 which is located on the side opposite the cover 41. The other end of the tube 1 may carry the cap 10, the closure cap 14, or in the case of operation in an inert gas atmosphere, the cap 11. In the case of this embodiment of the invention, the gas outlet comprises an opening 26 located as an aperture in the ground cover 41 of the cap 13, which can be closed by rotating the cover 41. A paper bridge 44 establishes the connection between the mobile phase located in the mobile phase trough 24 and the thin layer carrier 6.

Especially in the case of chromatography with thin layer carriers of various lengths, for example micro thin layer carriers, for application of descending, horizontal or continuous flow techniques, a cylindrical tripod stand 48 as shown in Figure 12 may be placed in the interior of the tube 1 or of the vessel 2 provided with the caps.

The cylindrical tripod stand 48 has at one end a depression 49 for the reception of a thin layer carrier. Another embodiment of the cylindrical stand 48 (Figure 13) carries a screwthread 50 which screws into a threaded sleeve 51. Both may be fitted with spacing spikes 53 so that they can be firmly located in the separating chamber. Alternatively the external diameter of the stand 48 may be made to closely correspond with the internal diameter of the tube 1 or of the vessel 2. In order to isolate substances out of the thin layer carriers, an exchangeable trough 25 may be inserted into the depression 49 of the cylindrical tripod stand 48. With such a trough it is possible to isolate substances out of the thin layer carriers by elution. For stability, the trough 25 bears a guide-bar 47 for insertion into a guide-tube 52 which is arranged in the hollow interior of the cylindrical tripod stand 48. Furthermore, in conjunction with the hollow cylindrical tripod stand 48 and with the use of the cap 10, direct isolation of substances out of thin layer carriers into the cap 10 is possible.

As already mentioned the tube 1 or the vessel 2 may be provided with spacing elements 8 or 9 arranged fixed or for insertion. One embodiment of the exchangeable spacing element 9 for retaining thin layer carriers, more particularly thin layer bars, renders possible the retention of four thin

layer bars 7, which may be inserted in normal or specially shaped construction. The exchangeable spacing element 9 (Figures 15 and 16) consists of a disc 55 with knurled handle 54. Apertures 56 are arranged at equal intervals and are each provided with a clamp spring 57 (only schematically indicated in Figure 16). The thin layer bars 7 are introduced into the apertures 56. The disc 55, by virtue of recesses 58, also renders possible, in case different lengths of thin layer carriers are retained by the exchangeable safety element 9, use of the latter in a multiple purpose separating chamber already provided with a fixed spacing element 8.

The various embodiments of the multiple separating chamber according to the invention may be fabricated of heat resistant and chemically resistant glass or of a material with equivalent properties. Fabrication of chemically resistant, more particularly solvent-resistant, transparent and also opaque materials, is possible especially in the case of the insertable troughs and other inserts.

WHAT WE CLAIM IS:—

1. A multiple purpose separating chamber of circular cross-section for the optional application of various operative techniques of thin layer chromatography, the chamber comprising a tube closed at at least one of its ends by a cap, one or more thin layer carriers being disposed in the tube and retained by spacing elements, the end or each end of the tube closed by a cap being arranged to form a ground joint with the cap, the said cap or one of the caps carrying a gas outlet.

2. A separating chamber as claimed in Claim 1, wherein the thin layer carriers are in the form of plates, films or bars.

3. A separating chamber as claimed in Claim 1 or 2, wherein the spacing elements are fixedly or removably arranged in the tube.

4. A separating chamber as claimed in Claim 1, 2 or 3, wherein the or each cap is interchangeable and constructed as a container for the reception of a mobile phase.

5. A separating chamber as claimed in any one of Claims 1 to 4, wherein one of the caps carries a gas inlet.

6. A separating chamber as claimed in any one of Claims 1 to 5, wherein the tube is connected at one end to a container branching from the tube at an acute angle, the container being adapted for closure and constructed for the reception of a mobile phase, and having a gas inlet and/or a gas outlet.

7. A separating chamber as claimed in Claim 4, wherein the caps are constructed

as containers for the reception of a mobile phase and are shaped as a hollow bulb with a circumferential channel.

8. A separating chamber as claimed in Claim 4, wherein the caps constructed as containers for the reception of a mobile phase are shaped —

a) as a part-spherical cap adapted for closure, having spike brackets arranged opposite one another on its interior wall and a trough for a mobile phase mounted interchangeably and rotatably between the spike brackets, or

b) as an elbow tube-like cap adapted for closure, having recesses for retaining an insertable trough for a mobile phase.

9. A separating chamber as claimed in any one of Claims 1 to 4, wherein the closure cap contains a passage for the insertion of the thin layer carrier.

10. A separating chamber as claimed in Claim 8a) wherein the trough for mobile phase supported interchangeably and rotatably between the spike brackets is provided on two mutually opposite sides with a T-shape groove for cooperating with the spike brackets to form the said mounting for the trough, and has a resilient clamp for retaining a bridge for the mobile phase.

11. A separating chamber as claimed in Claim 3, further including an interchangeable and if desired longitudinally adjustable hollow cylindrical tripod stand in its interior, said cylindrical tripod stand having at one end a depression for the reception of at least one thin layer carrier and a hollow guide tube arranged within the cylindrical tripod stand for the reception of a guide bar of an interchangeable trough for isolating substances out of the thin layer carriers.

12. A separating chamber as claimed in Claim 3, further including at least one interchangeable spacing element for retaining a plurality of thin layer carriers such as bar-shaped thin layer carriers in the interior space of the separating chamber, the spacing element comprising an apertured disc the apertures of which are arranged at an equal spacing on the disc and are provided with clamp springs for retaining the thin layer carriers.

13. Multiple purpose separating chambers for thin layer chromatography, substantially as herein described and with reference to any one of Figures 1, 3, 5 and 6 of the accompanying drawings.

VENNER, SHIPLEY & CO.,

Rugby Chambers, 2 Rugby Street,
London, W.C.1.

Chartered Patent Agents,

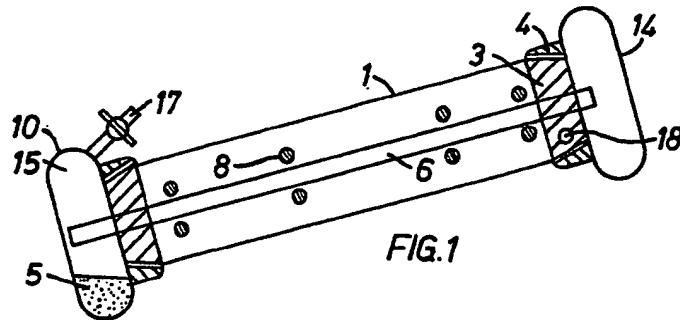

FIG. 1

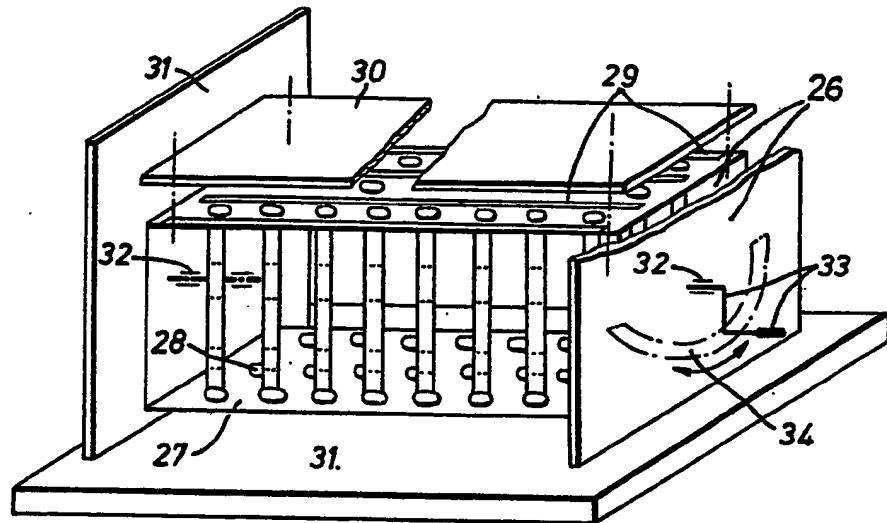

FIG. 2

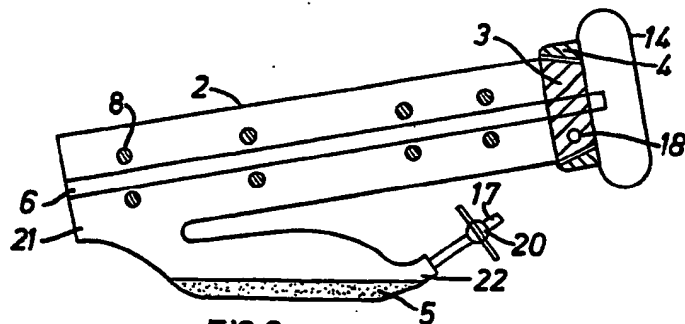

FIG. 3

1,232,104

4 SHEETS

COMPLETE SPECIFICATION

This drawing is a reproduction of the Original on a reduced scale.

SHEET 2

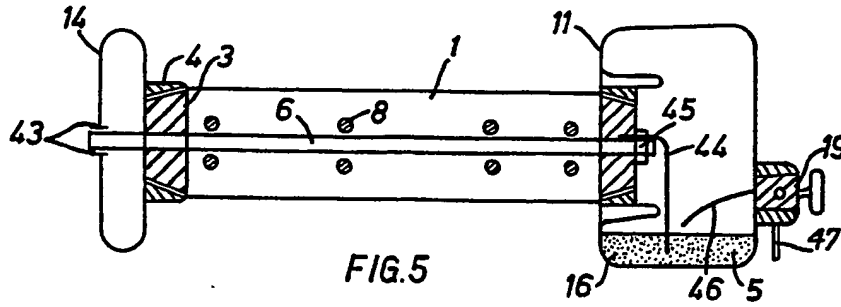

FIG. 5

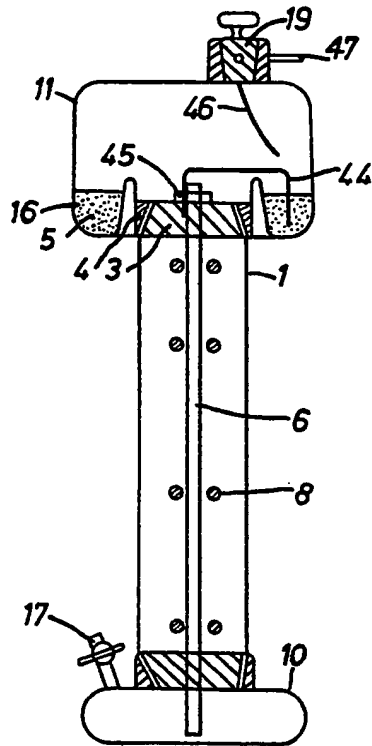

FIG. 4

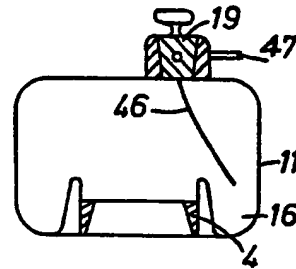

FIG. 6

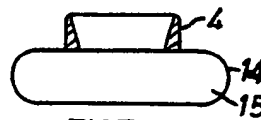

FIG. 7

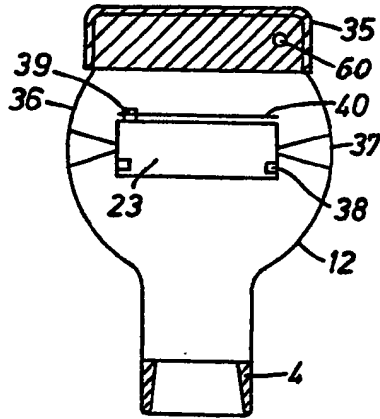

FIG. 8

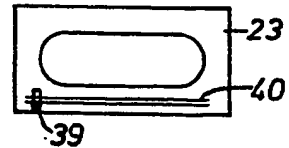

FIG. 9

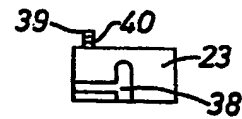

FIG. 9a

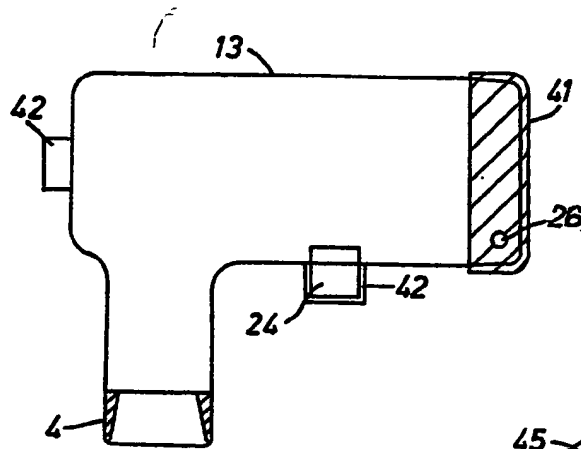

FIG. 10

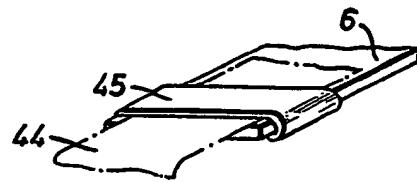

FIG. 11

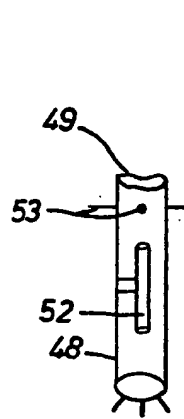

FIG. 12

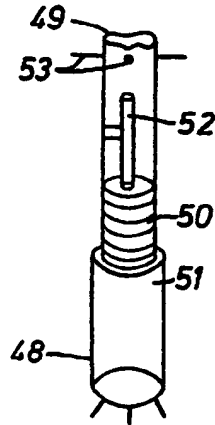

FIG. 13



FIG. 14

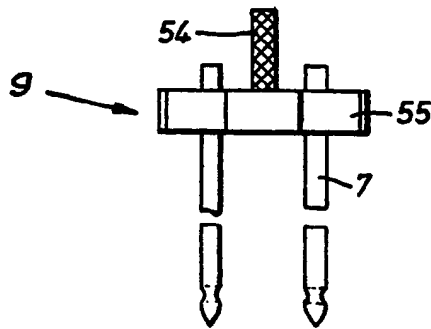

FIG. 15

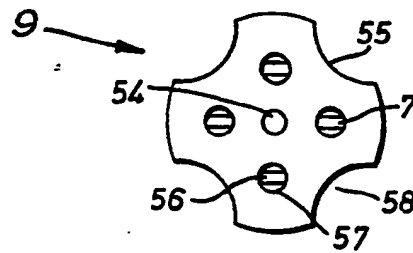

FIG. 16